

6739-11314 3-Tier Mesh Entryway Shoe Storage

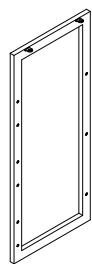

A 1 ea
Left Frame

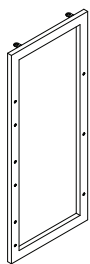

B 1 ea
Right Frame



C 3 ea
Mesh Shelves

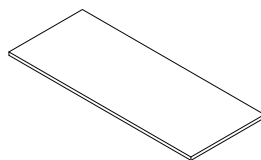

D 1 ea
Top



E 4 ea
Small Hex Screws



G 4 ea
Leveling Feet



F 12 ea
Hex Screws



H 1 ea
Hex Wrench

No Additional Tools Required

Please consider which of the following assembly options you prefer before you begin.

Option 1. Assemble as angled storage:
(Shelves slanted for shoes)

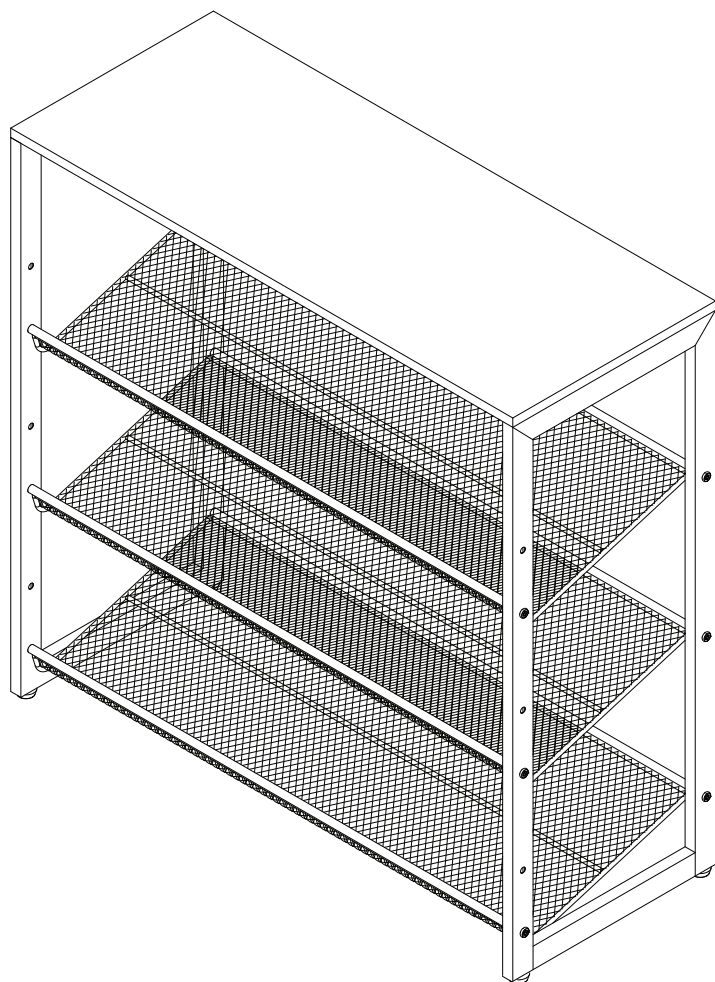

Option 2. Assemble as flat storage:
(Shelves level for clothing and accessories)

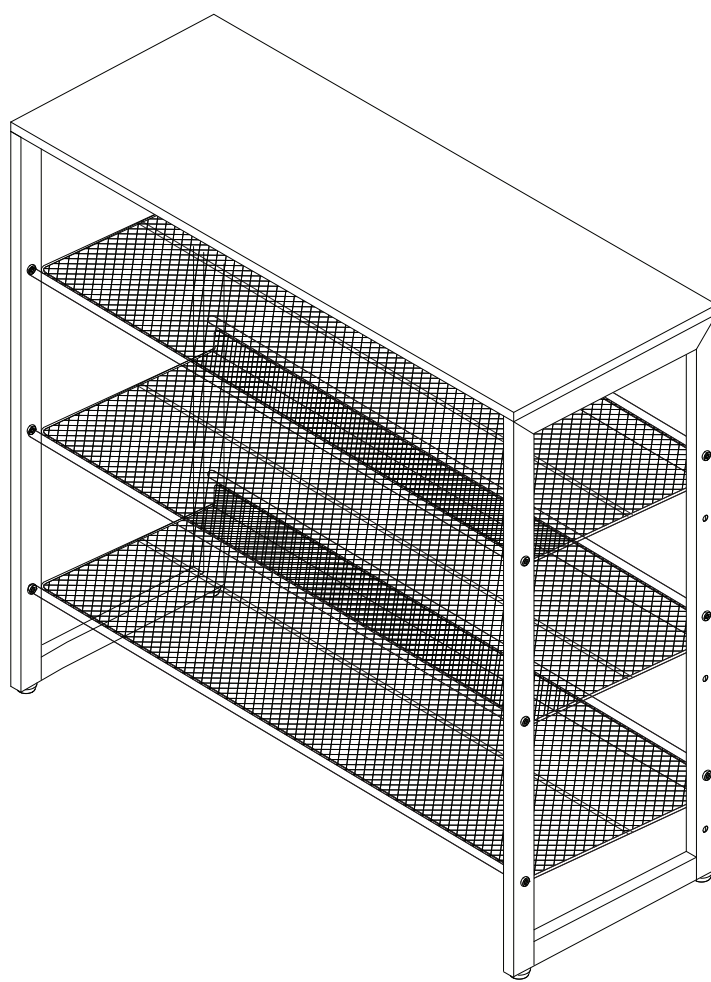

6739-11314 3-Tier Mesh Entryway Shoe Storage

Assemble as angled storage (option 1):

Step 1: Hand screw two leveling feet (**G**) into the bottoms of left and right frames (**A & B**).

Step 2: Attach side frames (**A & B**) to the mesh shelves (**C**) using 12 hex screws (**F**). Tighten with hex wrench (**H**).

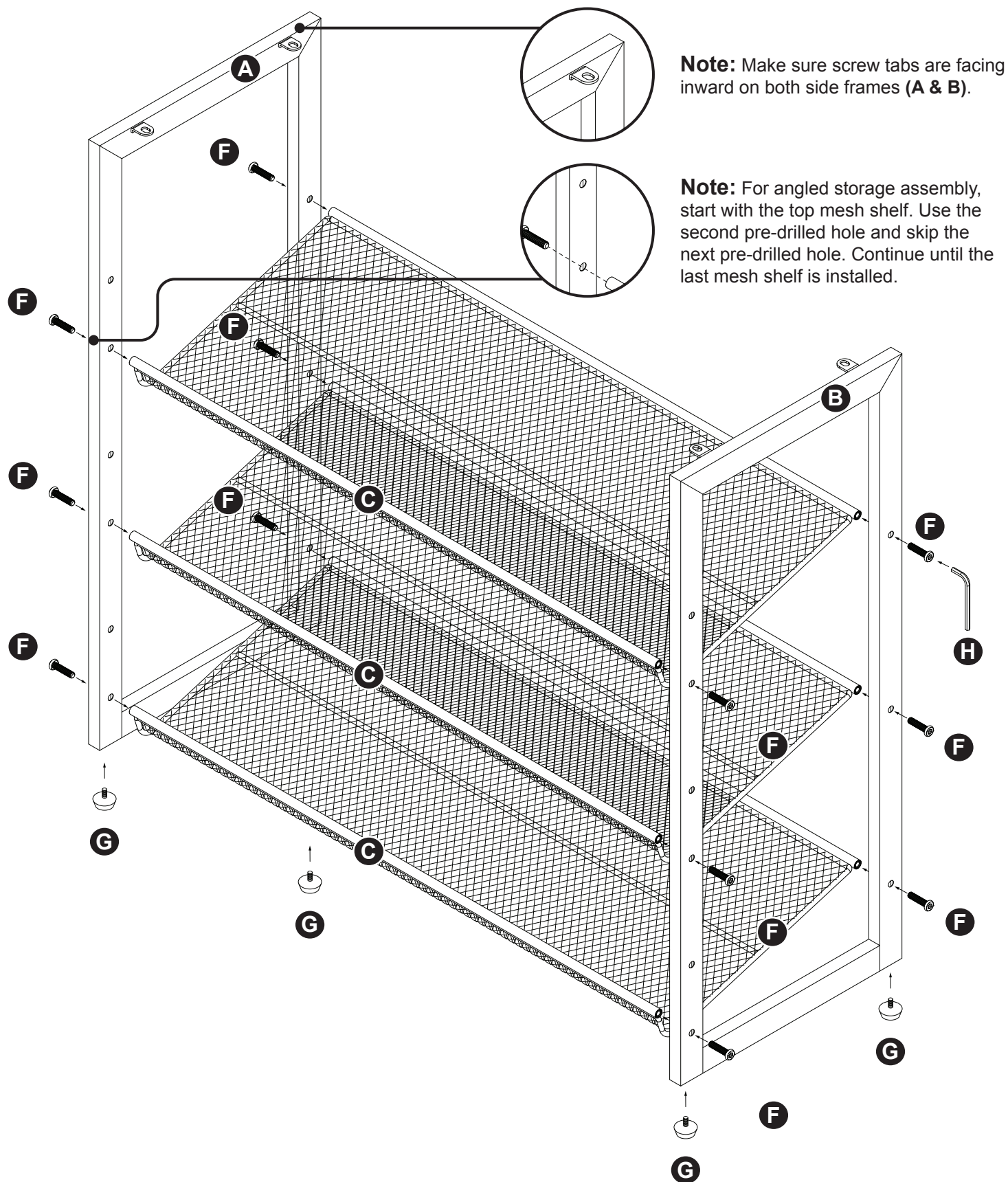

6739-11314 3-Tier Mesh Entryway Shoe Storage

Step 3: Attach top (D) to base using four small hex screws (E) and a hex wrench (H). Tighten the hex screws until the top is secure.

Step 4: Adjust leveling feet (G) as needed for stability.

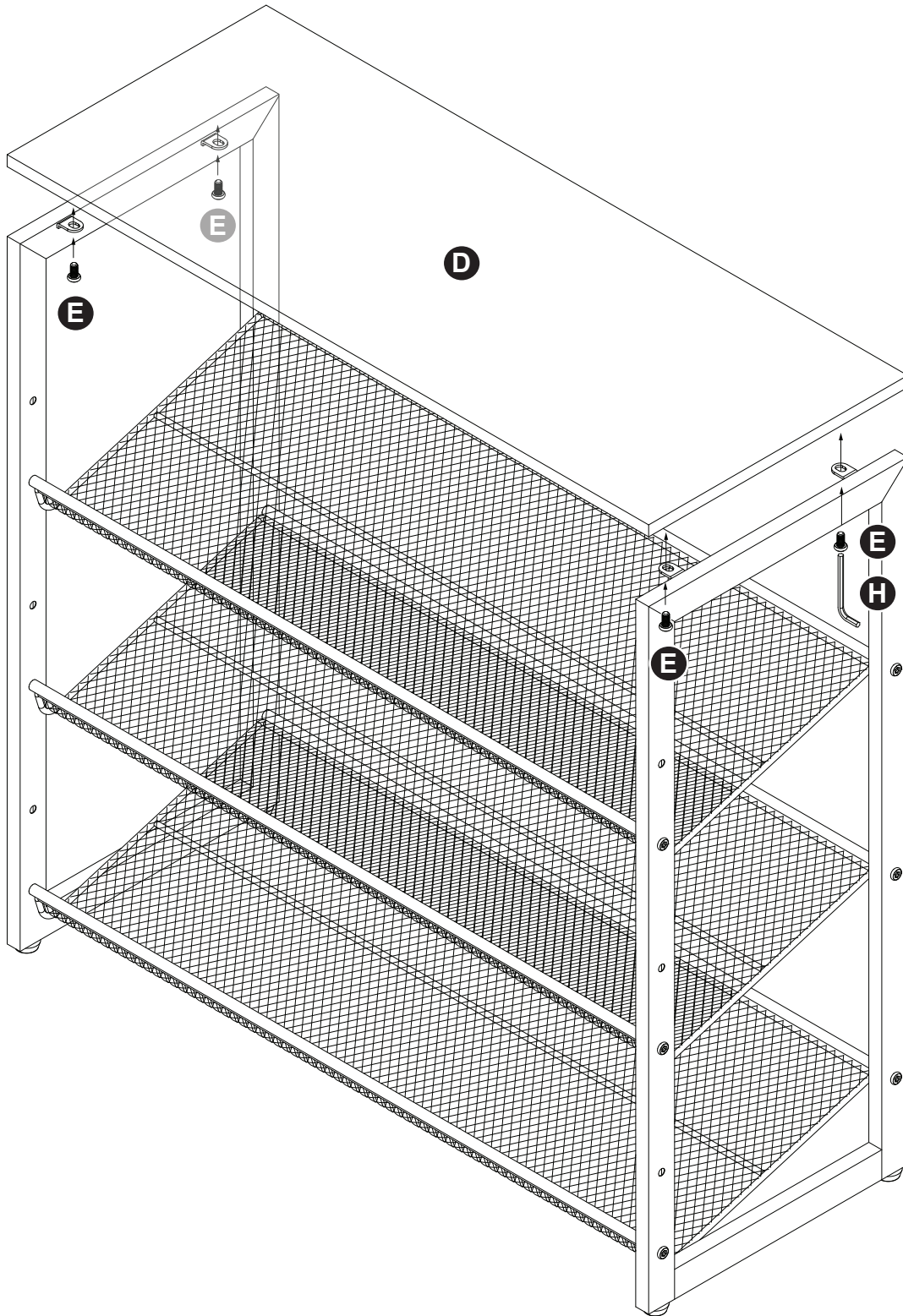

6739-11314 3-Tier Mesh Entryway Shoe Storage

Assemble as flat storage (option 2):

Step 1: Hand screw two leveling feet (G) into the bottoms of left and right frames (A & B).

Step 2: Attach side frames (A & B) to the mesh shelves (C) using 12 hex screws (F). Tighten with hex wrench (H).

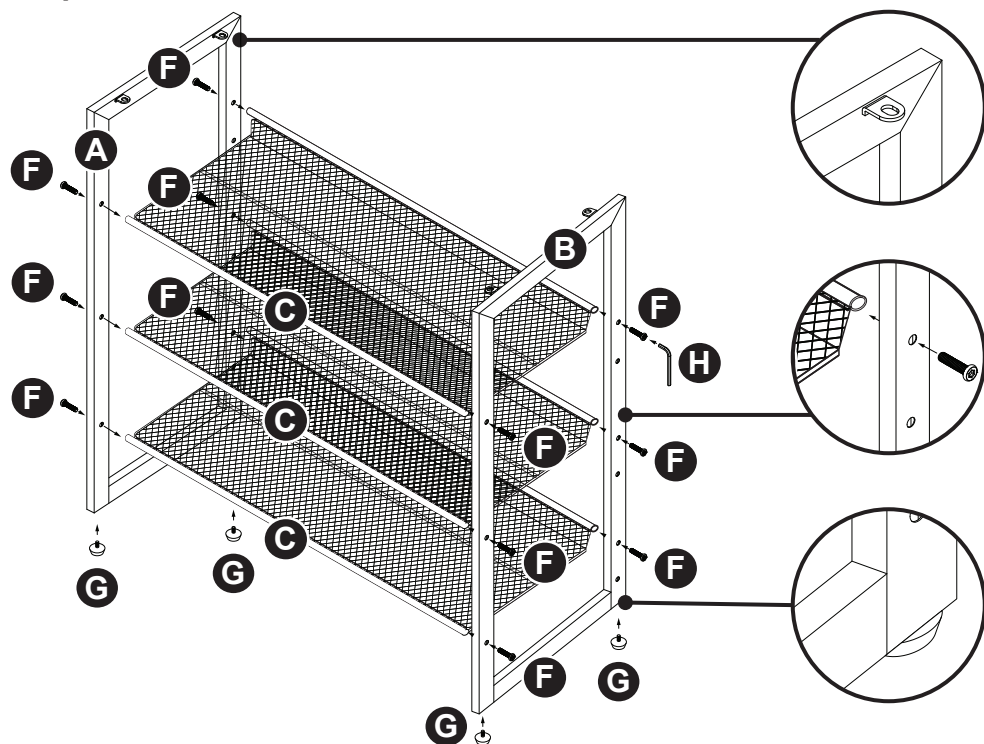

Note: Make sure screw tabs are facing inward on both side frames (A & B).

Note: For flat storage assembly, start with the top mesh shelf. Use the first pre-drilled hole and skip the next pre-drilled hole. Continue until the last mesh shelf is installed.

Note: Make sure feet are on the bottom on all frames.

Step 3: Attach top (D) to base using four small hex screws (E) and a hex wrench (H). Tighten the hex screws until the top is secure.

Step 4: Adjust leveling feet (G) as needed for stability.

