

elfa® Drawer Unit Assembly Instructions

DIAGRAM 1

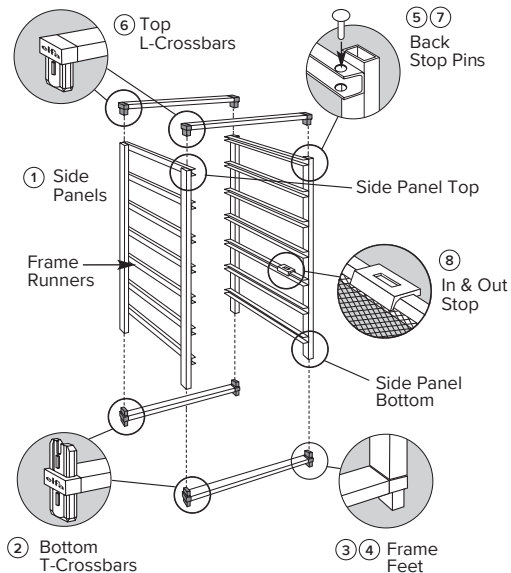

Tools needed: plastic mallet, 2 pieces of tape

TIPS FOR GETTING STARTED

- If you don't have a plastic mallet, you can use a hammer with a wood block or towel to protect the frame. Take care to protect the floor.

- ⚠ **Make sure you start with the T-Crossbar. Elfa Logo will read upside down in this position.**
- ⚠ **To keep Pins from "jumping" out of the holes while tapping the Top L-Crossbars in place, cover with a piece of tape.**

Assemble the Frame

- 1 Position the Side Panels with the runners facing inward.
- 2 Using a plastic mallet, tap the bottom T-Crossbar into the bottom of each Side Panel. **Make sure you start with the T-Crossbar. Elfa Logo will read upside down in this position.** See diagram 1. Alternate tapping each side to ensure T-Crossbar inserts smoothly.
- 3 Tap the four Frame Feet into place.
- 4 Flip Frame over so Feet are resting on the ground.
- 5 Put 2 Back Stop Pins in the back holes of the top runners. **To keep Pins from "jumping" out of the holes while tapping the Top L-Crossbars in place, cover with a piece of tape. The remaining Back Stop Pins should be put in place just prior to sliding in the Drawers.**

IF COMBINING FRAMES, SKIP TO PAGE 2 NOW.

- 6 Tap the Top L-Crossbars down part way, alternating sides, then remove the tape and tap completely into each Side Panel. If using a Melamine Top, place adhesive strips included in the packaging on the top of the Frame on all four corners. Remove paper backing. Position Top and press firmly to secure.

Add Drawers

- 7 Insert 2 Back Stop Pins for each Drawer and slide in Drawers.
 - 8 In/Out Stops keep your drawer from pulling completely out. Position the In/Out Stop so that the long side is inside the Drawer. Clip the short side of the In/Out Stop over the Frame Runner. Repeat on other side.
- If you have other accessories, add them now.

For assembly video, visit containerstore.com/elfa/installation

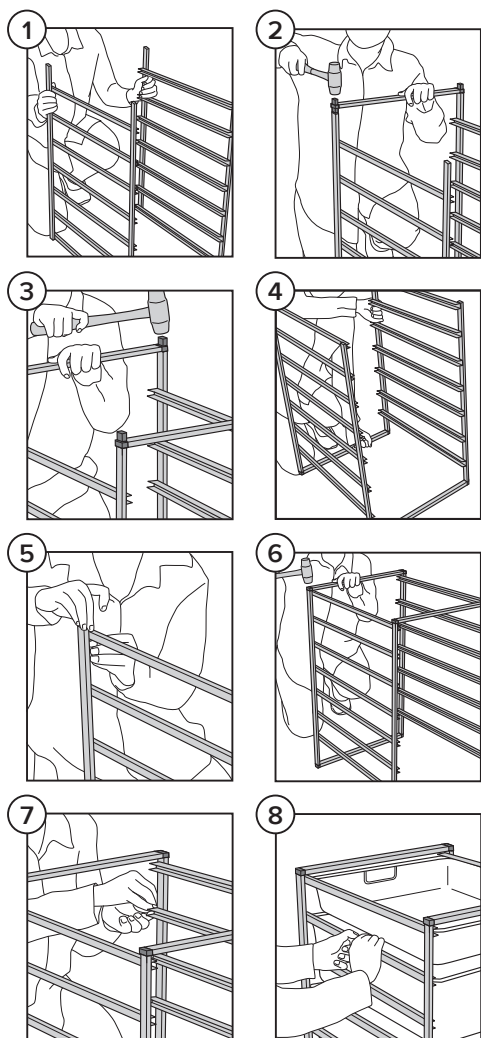

elfa® Drawer Unit Assembly Instructions

DIAGRAM 2

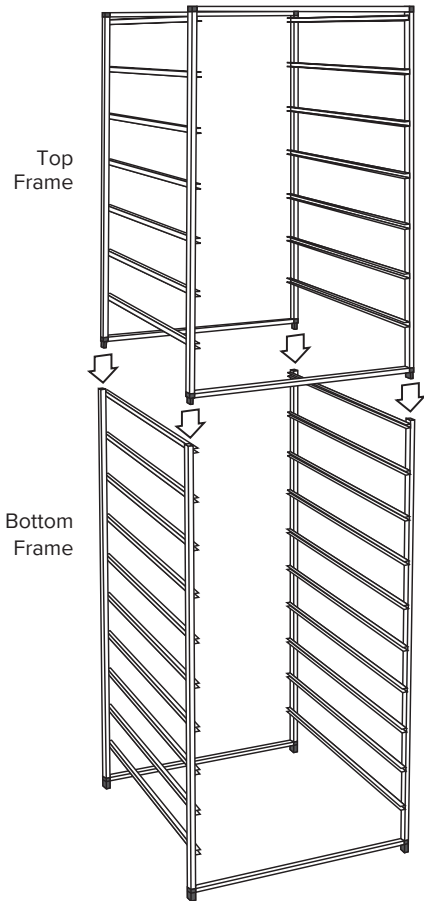

Combining Frames

- Assemble the top frame completely, omitting the Frame Feet (See instructions on page 1.)
- Assemble the bottom frame, omitting the Top L-Crossbars.
- Put 2 Back Stop Pins in the back holes of the top runners of the bottom frame. **To keep Pins from “jumping” out of the holes while tapping the Top L-Crossbars in place, cover with a piece of tape. The remaining Back Stop Pins should be put in place just prior to sliding in the Drawers.**
- Lower the top frame onto the bottom frame, making sure the top Back Stop Pins for both frames are all on the back side. Secure by firmly tapping each corner of the top frame until Bottom T-Crossbars are completely inserted into the bottom frame. See diagram 2.

Add Drawers

- 7 Insert 2 Back Stop Pins for each Drawer and slide in Drawers.
 - 8 In/Out Stops keep your drawer from pulling completely out. Position the In/Out Stop so that the long side is inside the Drawer. Clip the short side of the In/Out Stop over the Frame Runner. Repeat on other side.
- If you have other accessories, add them now.

For assembly video, visit [containerstore.com/elfa/installation](https://www.containerstore.com/elfa/installation)

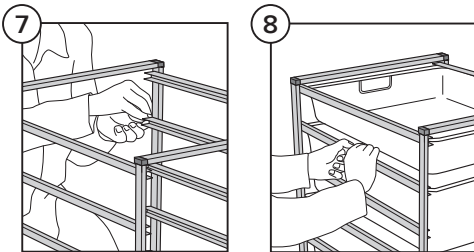

ONLY AT **The Container Store®**